

## SM100 Technical specifications

Rated Operating Capacity @35%	1,000 lb
Tipping load	2,857 lb
Operating weight	3,300 lb
Travel speed	5.2 mph
Operating pressure - ground	4.1 psi
Flow rate - auxiliary	13 US gpm
Pressure - auxiliary	3,045 psi
Engine / Motor	Yanmar 3TNV80FT
Engine / Motor type	liquid-cooled, 4-cycle, 3-cylinder, turbocharged diesel engine
Power	24.7 hp
Torque - max. @1800 rpm	62.6 lbf
Idling speed low	1,200 rpm
Idling speed high	2,600 rpm
Fuel tank capacity	14.1 US gal

## SM100 Dimensions

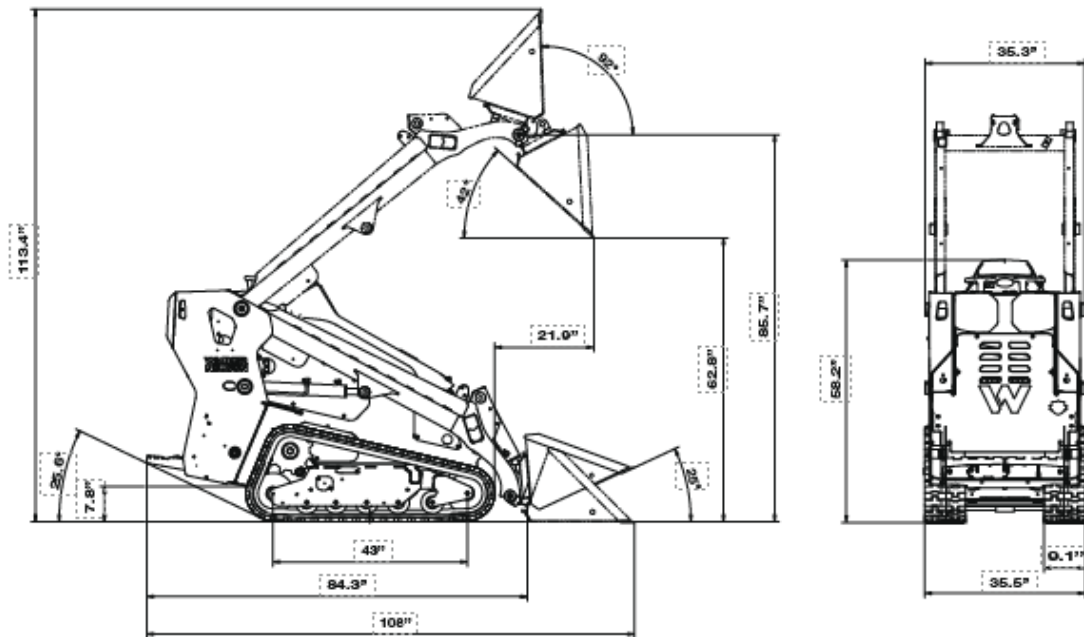

Overall length with bucket	108 in
Overall length without bucket	84.8 in
Overall width	35.5 in
Overall height	58.2 in
Hinge pin height	85.7 in
Dump height max.	62.8 in
Bucket rollback at ground level	25 °
Bucket rollback at max. stroke height	92 °
Dump angle at max height	42 °
Ground clearance	7.8 in
Track length on ground	43 in
Angle of departure	25.6 °

Please note: that product availability can vary from country to country. It is possible that information / products may not be available in your country. More detailed information on engine power can be found in the operator's manual; the stated power may vary due to specific operating conditions. Subject to alterations and errors excepted. Applicable also to illustrations.

Copyright © 2022 Wacker Neuson SE.